

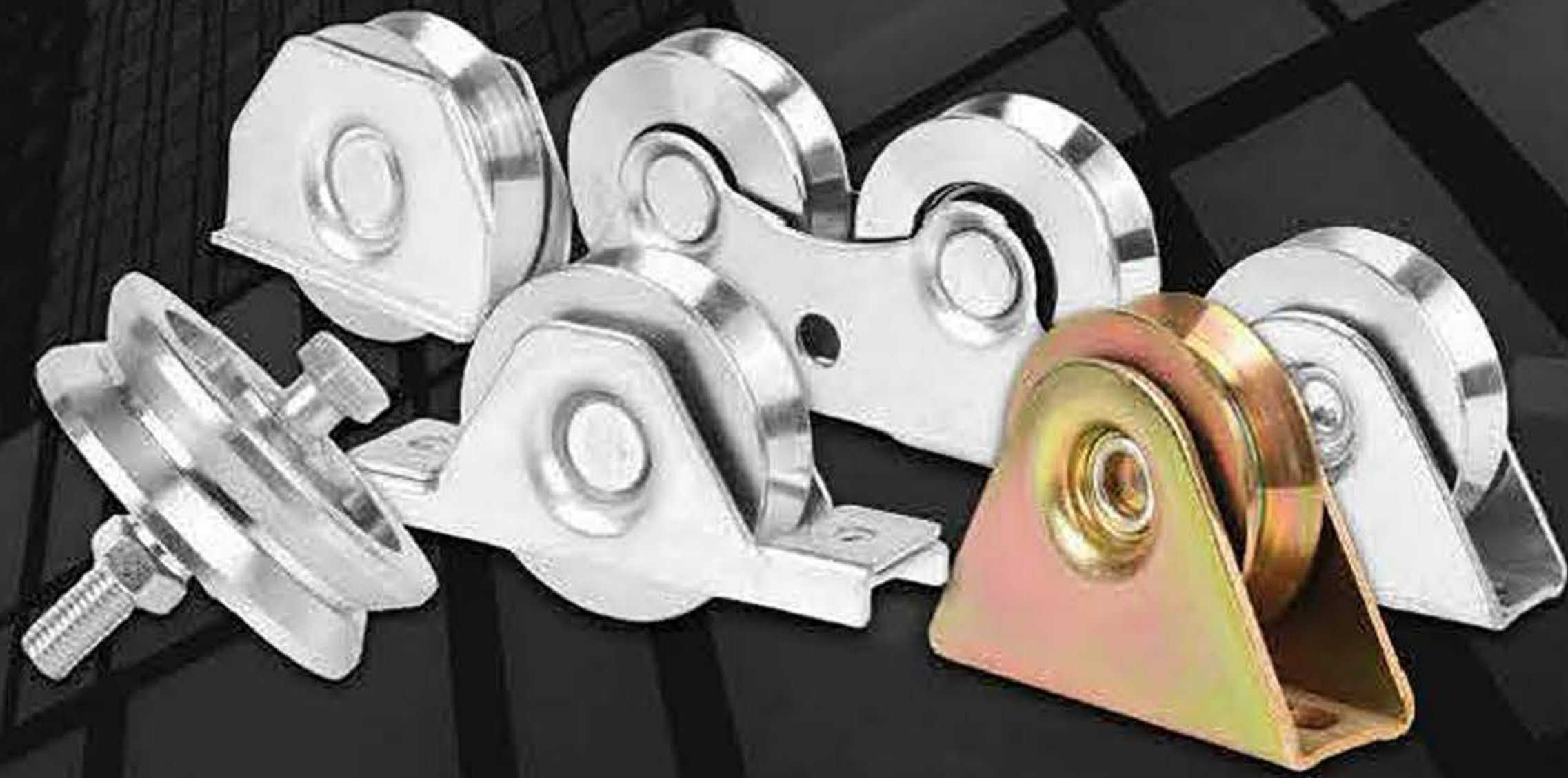

欧耐达



设计/研发/生产/销售
吊轮、吊轨、滑轮、滑轨、尼龙轮等五金配件
OEM | ODM | OBM

天津欧耐达传动科技有限公司
Tianjin OuNaiDa Transmissions Technology Co., Ltd



Designed for **Residential**
and **Commercial** Gates

- ✔ High Traffic Capability
- ✔ Load Capacity up to 800 lbs.
- ✔ Fits 90° V-Shape Track
- ✔ Low Noise



Product Display 产品展示

▼ 螺杆滑轮 (Y槽) Sliding Gate Wheel With Bolt (Y-groove)

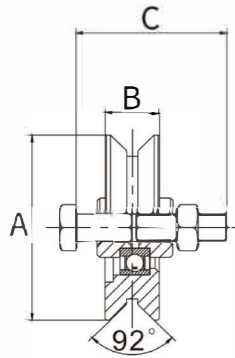

型号 Item	A	B	C	单重 (KG)	每箱数量 PCS/CTN	纸箱尺寸 CTN	备注 Remark
A1Y40	φ38	12	M8*50	0.05	150	29*17*19CM	单轴承
A1Y50	φ48	15	M10*55	0.15	80	29*17*19CM	单轴承
A1Y60	φ58	17	M10*55	0.27	80	29*17*19CM	单轴承
A1Y70	φ68	20	M12*55	0.42	40	29*17*19CM	单轴承
A1Y80	φ78	20	M12*55	0.61	40	29*17*19CM	单轴承
A1Y90	φ88	20	M12*55	0.77	20	29*17*19CM	单轴承
A1Y100	φ98	20	M12*55	1	20	29*17*19CM	单轴承
A2Y120	φ118	25	M4*80	1.8	10	29*17*19CM	双轴承
A2Y140	φ138	25	M4*80	2.7	8	29*17*19CM	双轴承
A2Y160	φ158	30	M4*80	4.1	6	29*17*19CM	双轴承

▼ 梯形滑轮 (Y槽) Sliding Gate Wheel Exterior Bracket(Y-groove)

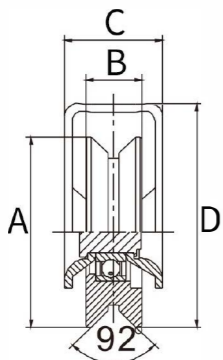

型号 Item	A	B	C	D	单重 (KG)	每箱数量 PCS/CTN	纸箱尺寸 CTN	备注 Remark
B1Y30	φ28	10	17	34	0.063	150	29*17*19CM	单轴承
B1Y40	φ38	12	20	43	0.12	120	29*17*19CM	单轴承
B1Y50	φ48	15	28	62	0.29	60	29*17*19CM	单轴承
B1Y60	φ58	17	28	67	0.4	50	29*17*19CM	单轴承
B1Y70	φ68	20	34	79	0.65	30	29*17*19CM	单轴承
B1Y80	φ78	20	34	84	0.8	30	29*17*19CM	单轴承
B1Y90	φ88	20	36	102	1.1	15	29*17*19CM	单轴承
B1Y100	φ98	20	36	107	1.35	15	29*17*19CM	单轴承
B1Y120	φ118	25	38	126	2.3	10	29*17*19CM	双轴承

▼ 叠片滑轮 (Y槽) Sliding Gate Wheel Interior Bracket (Y-groove)

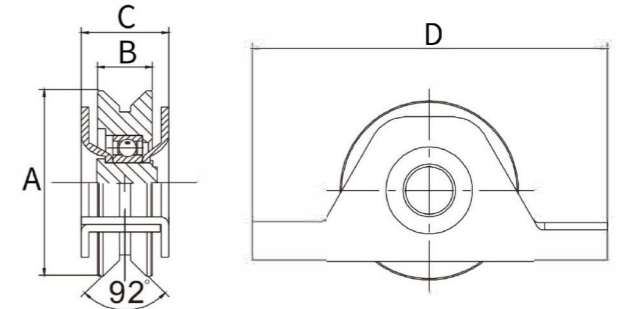

型号 Item	A	B	C	D	单重 (KG)	每箱数量 PCS/CTN	纸箱尺寸 CTN	备注 Remark
C1Y50	φ48	15	26	100	0.25	50	29*17*19CM	单轴承
C1Y60	φ58	17	26	100	0.36	50	29*17*19CM	单轴承
C1Y70	φ68	20	33	135	0.58	30	29*17*19CM	单轴承
C1Y80	φ78	20	33	135	0.75	30	29*17*19CM	单轴承
C1Y90	φ88	20	33	152	1.05	15	29*17*19CM	单轴承
C1Y100	φ98	20	33	152	1.2	15	29*17*19CM	单轴承
C1Y120	φ118	25	36	201	2.8	10	29*17*19CM	双轴承

▼ 夹片滑轮 (Y槽) Sliding Gate Wheel with plate (Y-groove)

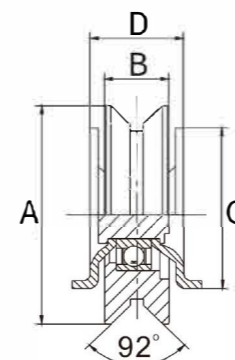

型号 Item	A	B	C	D	单重 (KG)	每箱数量 PCS/CTN	纸箱尺寸 CTN
DIY50	φ48	15	41	38	0.17	50	29*17*19CM
DIY60	φ58	17	41	38	0.32	50	29*17*19CM
DIY70	φ68	20	51	44	0.5	30	29*17*19CM
DIY80	φ78	20	51	44	0.7	30	29*17*19CM
DIY90	φ88	20	67	44	1	15	29*17*19CM
DIY100	φ98	20	67	44	1.25	15	29*17*19CM
DIY120	φ120	20	67	44	1.89	12	29*17*19CM

▼ 螺杆滑轮 (V槽) Sliding Gate Wheel With Bolt (V-groove)

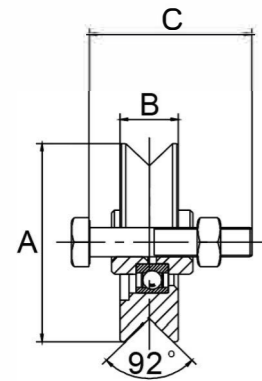

型号 Item	A	B	C	单重 (KG)	每箱数量 PCS/CTN	纸箱尺寸 CTN	备注 Remark
A1V40	φ38	12	M8*50	0.1	150	29*17*19CM	单轴承
A1V50	φ48	15	M10*55	0.15	80	29*17*19CM	单轴承
A1V60	φ58	17	M10*55	0.3	80	29*17*19CM	单轴承
A1V70	φ68	20	M12*55	0.48	40	29*17*19CM	单轴承
A1V80	φ78	20	M12*55	0.64	40	29*17*19CM	单轴承
A1V90	φ88	20	M12*55	0.83	20	29*17*19CM	单轴承
A1V100	φ98	20	M12*55	1	20	29*17*19CM	单轴承
A2V120	φ118	25	M4*80	1.8	10	29*17*19CM	双轴承
A2V140	φ138	25	M4*80	2.7	8	29*17*19CM	双轴承
A2V160	φ158	30	M4*80	4.1	6	29*17*19CM	双轴承

▼ 梯形滑轮 (V槽) Sliding Gate Wheel Exterior Bracket (V-groove)

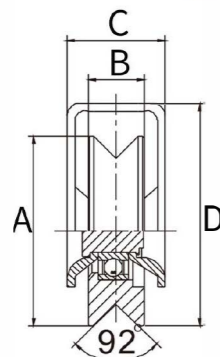

型号 Item	A	B	C	D	单重 (KG)	每箱数量 PCS/CTN	纸箱尺寸 CTN	备注 Remark
B1V30	φ28	10	17	34	0.063	150	29*17*19CM	单轴承
B1V40	φ38	12	20	43	0.12	120	29*17*19CM	单轴承
B1V50	φ48	15	28	62	0.29	60	29*17*19CM	单轴承
B1V60	φ58	17	28	67	0.4	50	29*17*19CM	单轴承
B1V70	φ68	20	34	79	0.65	30	29*17*19CM	单轴承
B1V80	φ78	20	34	84	0.82	30	29*17*19CM	单轴承
B1V90	φ88	20	36	102	1.1	15	29*17*19CM	单轴承
B1V100	φ98	20	36	107	1.35	15	29*17*19CM	单轴承
B1V120	φ118	25	38	126	2.3	10	29*17*19CM	双轴承

▼ 叠片滑轮 (V槽) Sliding Gate Wheel Interior Bracket (V-groove)

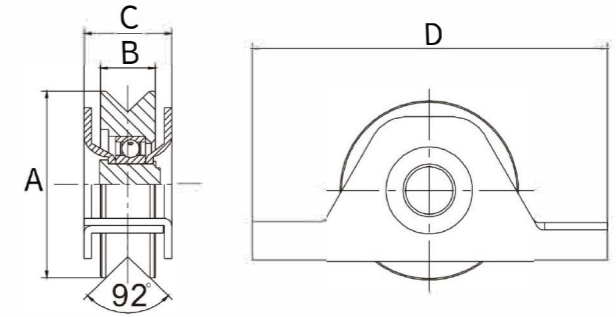

型号 Item	A	B	C	D	单重 (KG)	每箱数量 PCS/CTN	纸箱尺寸 CTN	备注 Remark
C1V50	φ48	15	26	100	0.25	50	29*17*19CM	单轴承
C1V60	φ58	17	26	100	0.36	50	29*17*19CM	单轴承
C1V70	φ68	20	33	135	0.58	30	29*17*19CM	单轴承
C1V80	φ78	20	33	135	0.75	30	29*17*19CM	单轴承
C1V90	φ88	20	33	152	1.05	15	29*17*19CM	单轴承
C1V100	φ98	20	33	152	1.2	15	29*17*19CM	单轴承
C1V120	φ118	25	36	201	2.18	10	29*17*19CM	双轴承

▼ 夹片滑轮 (V槽) Sliding Gate Wheel with plate (V-groove)

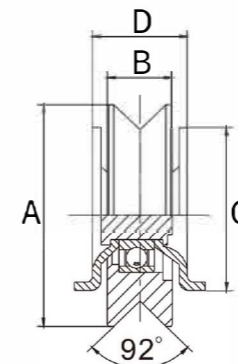

型号 Item	A	B	C	D	单重 (KG)	每箱数量 PCS/CTN	纸箱尺寸 CTN
D1V50	φ48	15	41	38	0.17	50	29*17*19CM
D1V60	φ58	17	41	38	0.32	50	29*17*19CM
D1V70	φ68	20	51	44	0.5	30	29*17*19CM
D1V80	φ78	20	51	44	0.7	30	29*17*19CM
D1V90	φ88	20	67	44	1	15	29*17*19CM
D1V100	φ98	20	67	44	1.25	15	29*17*19CM
D1V120	φ120	20	67	44	1.89	12	29*17*19CM

▼ 螺杆滑轮 (U槽) Sliding Gate Wheel With Bolt (U-groove)

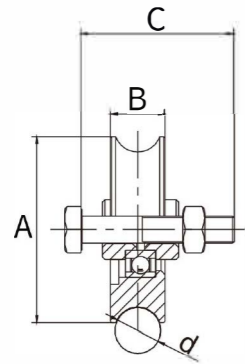

型号 Item	A	B	C	单重 (KG)	每箱数量 PCS/CTN	纸箱尺寸 CTN	备注 Remark
A1U40	φ38	12	M8*50	0.11	150	29*17*19CM	单轴承
A1U50	φ48	15	M10*55	0.14	80	29*17*19CM	单轴承
A1U60	φ58	17	M10*55	0.26	80	29*17*19CM	单轴承
A1U70	φ68	20	M12*55	0.45	40	29*17*19CM	单轴承
A1U80	φ78	20	M12*55	0.61	40	29*17*19CM	单轴承
A1U90	φ88	20	M12*55	0.8	20	29*17*19CM	单轴承
A1U100	φ98	20	M12*55	1	20	29*17*19CM	单轴承
A2U120	φ118	25	M4*80	1.8	10	29*17*19CM	双轴承
A2U140	φ138	25	M4*80	2.6	8	29*17*19CM	双轴承
A2U160	φ158	30	M4*80	4	6	29*17*19CM	双轴承

▼ 梯形滑轮 (U槽) Sliding Gate Wheel Exterior Bracket(U-groove)

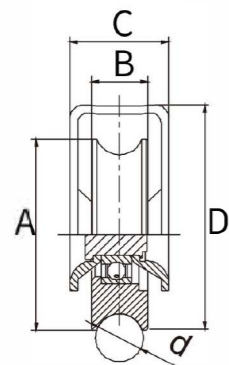

型号 Item	A	B	C	D	单重 (KG)	每箱数量 PCS/CTN	纸箱尺寸 CTN	备注 Remark
B1U30	φ28	10	17	34	0.05	150	29*17*19CM	单轴承
B1U40	φ38	12	20	43	0.1	120	29*17*19CM	单轴承
B1U50	φ48	15	28	62	0.27	60	29*17*19CM	单轴承
B1U60	φ58	17	28	67	0.39	50	29*17*19CM	单轴承
B1U70	φ68	20	34	79	0.65	30	29*17*19CM	单轴承
B1U80	φ78	20	34	84	0.81	30	29*17*19CM	单轴承
B1U90	φ88	20	36	102	1.1	15	29*17*19CM	单轴承
B1U100	φ98	20	36	107	1.3	15	29*17*19CM	单轴承
B1U120	φ118	25	38	126	2.25	10	29*17*19CM	双轴承

▼ 叠片滑轮 (U槽) Sliding Gate Wheel Interior Bracket (U-groove)

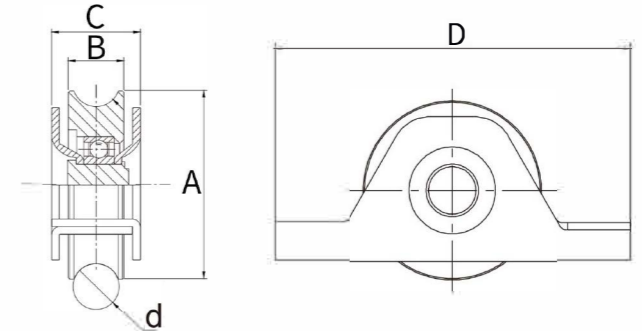
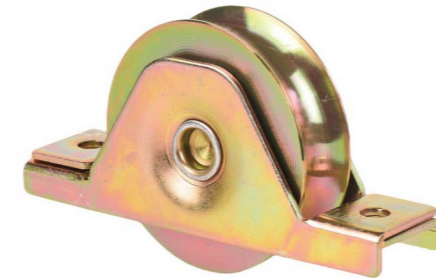

型号 Item	A	B	C	D	单重 (KG)	每箱数量 PCS/CTN	纸箱尺寸 CTN	备注 Remark
C1U50	φ48	15	26	100	0.24	50	29*17*19CM	单轴承
C1U60	φ58	17	26	100	0.36	50	29*17*19CM	单轴承
C1U70	φ68	20	33	135	0.56	30	29*17*19CM	单轴承
C1U80	φ78	20	33	135	0.73	30	29*17*19CM	单轴承
C1U90	φ88	20	33	152	1	15	29*17*19CM	单轴承
C1U100	φ98	20	33	152	1.15	15	29*17*19CM	单轴承
C1U120	φ118	25	36	201	2.15	10	29*17*19CM	双轴承

▼ 夹片滑轮 (U槽) Sliding Gate Wheel with plate (U-groove)

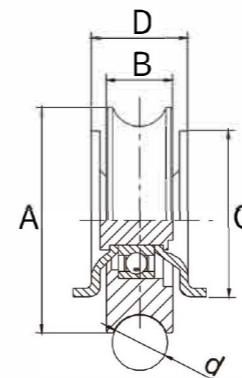

型号 Item	A	B	C	D	单重 (KG)	每箱数量 PCS/CTN	纸箱尺寸 CTN
DIU50	φ48	15	41	38	0.3	50	29*17*19CM
DIU60	φ58	17	41	38	0.32	50	29*17*19CM
DIU70	φ68	20	51	44	0.497	30	29*17*19CM
DIU80	φ78	20	51	44	0.65	30	29*17*19CM
DIU90	φ88	20	67	44	0.85	15	29*17*19CM
DIU100	φ98	20	67	44	1.2	15	29*17*19CM
DIU120	φ120	20	67	44	1.6	12	29*17*19CM

▼ 带螺杆V槽双轴承滑轮 Sliding Gate Wheel with Bolt (Double bearing, V groove)

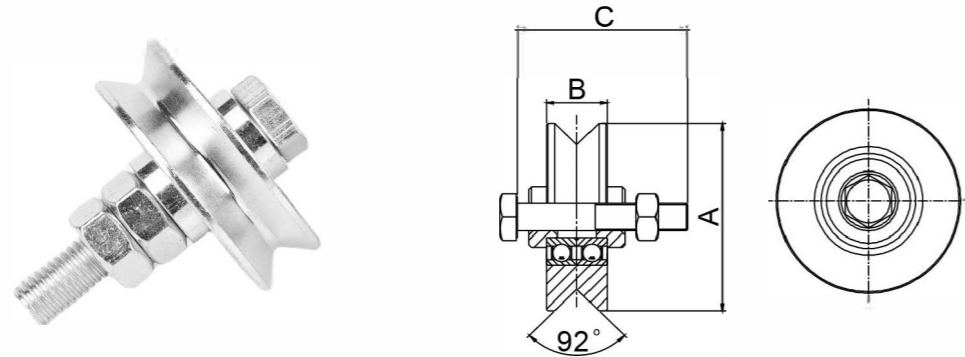

型号 Item	A	B	C	单重 (KG)	每箱数量 PCS/CTN	纸箱尺寸 CTN	备注 Remark
A2V50	φ48	20	M10×55	0.2	60	29*17*19CM	双轴承
A2V60	φ58	20	M10×55	0.31	50	29*17*19CM	双轴承
A2V70	φ68	23	M12×70	0.54	30	29*17*19CM	双轴承
A2V80	φ78	23	M12×70	0.73	30	29*17*19CM	双轴承
A2V90	φ88	24	M12×70	1.03	15	29*17*19CM	双轴承
A2V100	φ98	24	M12×70	1.28	15	29*17*19CM	双轴承
A2V120	φ118	25	M12×70	1.98	10	29*17*19CM	双轴承
A2V140	φ138	30	M14×70	3.15	8	29*17*19CM	双轴承
A2V160	φ158	30	M14×70	4.19	6	29*17*19CM	双轴承
A2V180	φ178	30	M14×70	5.43	4	29*17*19CM	双轴承
A2V200	φ198	30	M14×70	6.73	4	29*17*19CM	双轴承

▼ 梯形滑轮 (Y槽双轴承) Sliding Gate Wheel Exterior Bracket (Y-groove double bearing)

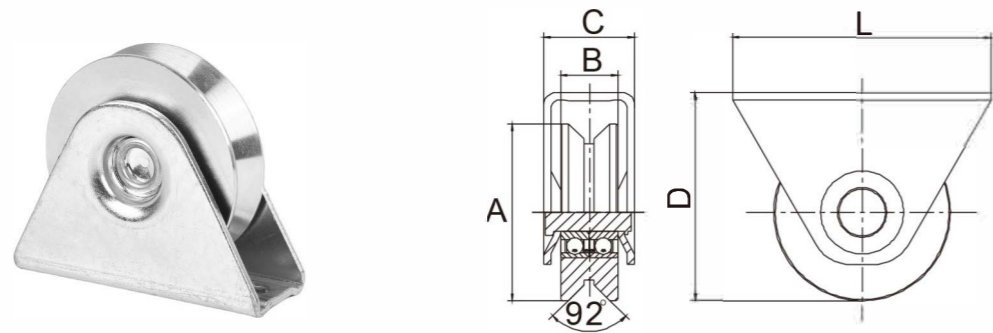

型号 Item	A	B	C	D	单重 (KG)	每箱数量 PCS/CTN	纸箱尺寸 CTN	备注 Remark
B2Y50	φ48	20	28	62	0.32	60	29*17*19CM	双轴承
B2Y60	φ58	20	28	67	0.5	50	29*17*19CM	双轴承
B2Y70	φ68	23	34	79	0.72	30	29*17*19CM	双轴承
B2Y80	φ78	23	34	84	0.85	30	29*17*19CM	双轴承
B2Y90	φ88	24	36	102	1.28	15	29*17*19CM	双轴承
B2Y100	φ98	24	36	107	1.5	15	29*17*19CM	双轴承
B2Y120	φ118	25	38	126	2.3	10	29*17*19CM	双轴承

▼ 叠片滑轮 (Y槽双轴承) Sliding Gate Wheel Interior Bracket (Y-groove double bearing)

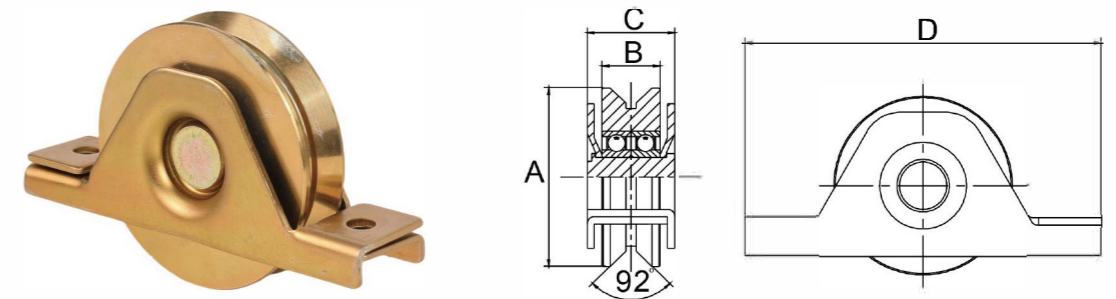

型号 Item	A	B	C	D	单重 (KG)	每箱数量 PCS/CTN	纸箱尺寸 CTN	备注 Remark
C2Y70	φ68	23	33	135	0.68	30	29*17*19CM	双轴承
C2Y80	φ78	23	33	135	0.85	30	29*17*19CM	双轴承
C2Y90	φ88	24	33	152	1.2	15	29*17*19CM	双轴承
C2Y100	φ98	24	33	152	1.4	15	29*17*19CM	双轴承
C2Y120	φ118	25	36	201	2.2	10	29*17*19CM	双轴承

▼ 夹片滑轮 (Y槽双轴承) Sliding Gate Wheel with plate (Y-groove double bearing)

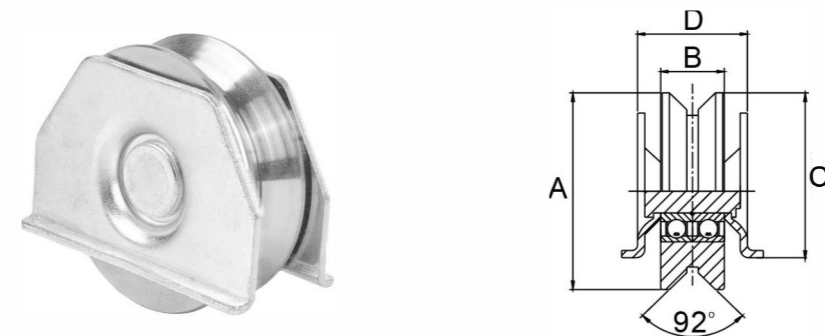

型号 Item	A	B	C	D	单重 (KG)	每箱数量 PCS/CTN	纸箱尺寸 CTN	备注 Remark
D2Y50	φ48	20	41	41	0.32	50	29*17*19CM	双轴承
D2Y60	φ58	20	41	41	0.35	50	29*17*19CM	双轴承
D2Y70	φ68	23	51	47	0.54	30	29*17*19CM	双轴承
D2Y80	φ78	23	51	47	0.72	30	29*17*19CM	双轴承
D2Y90	φ88	24	67	47	1.08	15	29*17*19CM	双轴承
D2Y100	φ98	24	67	47	1.4	15	29*17*19CM	双轴承
D2Y120	φ118	25	67	47	2.1	10	29*17*19CM	双轴承

▼ 两用滑轮 Sliding Gate Wheel with Exterior Bracket

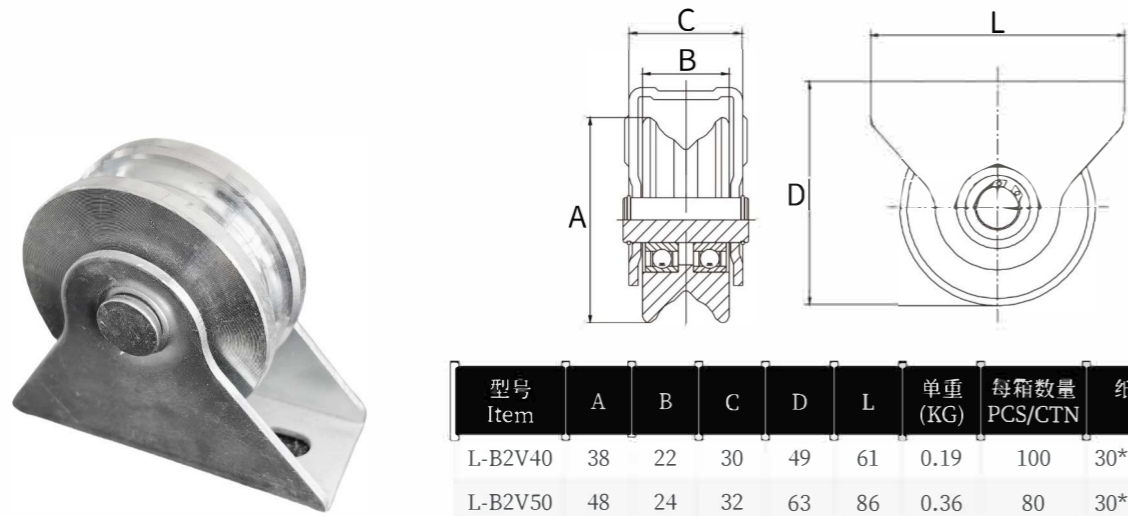

型号 Item	A	B	C	D	L	单重 (KG)	每箱数量 PCS/CTN	纸箱尺寸 CTN
L-B2V40	38	22	30	49	61	0.19	100	30*30*13CM
L-B2V50	48	24	32	63	86	0.36	80	30*30*13CM
L-B2V60	58	24	32	68	86	0.46	50	30*30*13CM
L-B2V70	68	26	36	84	100	0.77	20	30*30*13CM
L-B2V80	78	26	36	89	100	0.99	20	30*30*13CM

▼ 非洲款双轴承滑轮 Sliding Gate Wheel with Exterior Bracket

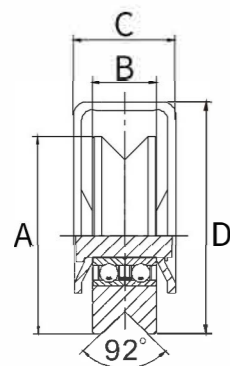
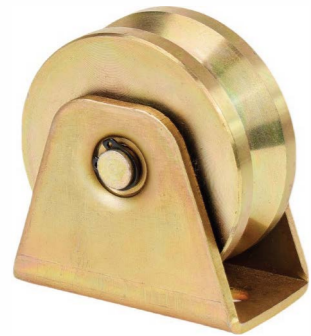

型号 Item	A	B	C	D	单重 (KG)	每箱数量 PCS/CTN	纸箱尺寸 CTN
S-B2V40	38	21	30	48	0.24	80	30*30*15CM
S-B2V50	48	26	35	53	0.31	80	30*30*15CM
S-B2V60	58	26	44	58	0.6	50	30*30*15CM
S-B2V70	68	32	44	79	0.95	30	30*30*15CM
S-B2V80	78	32	44	84	1.2	25	30*30*15CM
S-B2V90	88	32	46	100	1.7	15	30*30*15CM
S-B2V100	98	32	46	105	2.1	15	30*30*15CM

▼ 双轮滑轮 Sliding Gate Wheel with Exterior Bracket

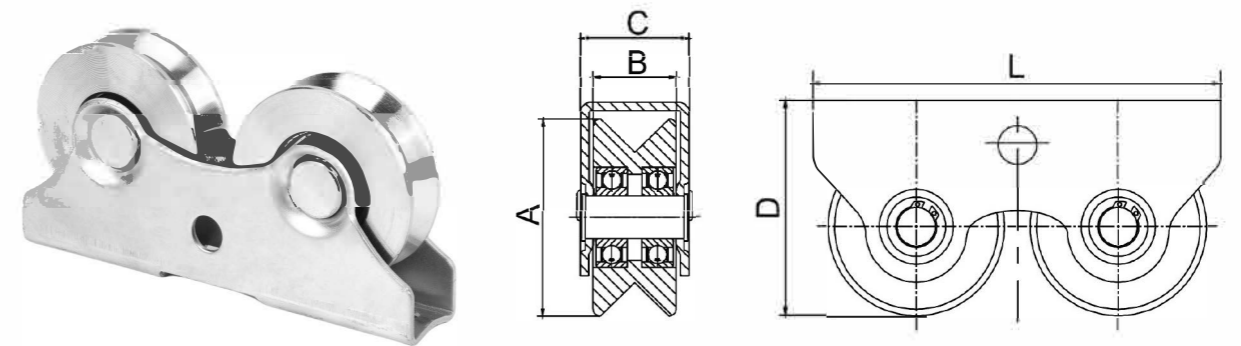

型号 Item	A	B	C	D	L	单重 (KG)	每箱数量 PCS/CTN	纸箱尺寸 CTN
D-B2V40	38	21	31	54	108	0.37	40	30*30*15CM
D-B2V50	48	24	33	59	129	0.67	40	30*30*15CM
D-B2V60	58	24	33	64	129	0.85	30	30*30*15CM
D-B2V70	68	26	34	78	158	1.35	20	30*30*15CM
D-B2V80	78	26	34	83	158	1.88	20	30*30*15CM
D-B2V90	88	28	36	88	198	2.6	12	30*30*15CM
D-B2V100	98	28	36	93	198	3.15	12	30*30*15CM

▼ 滚花轴滑轮 Sliding Gate Wheel with Pin (Single Bearing, V groove)

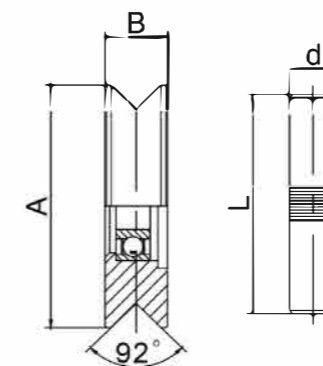
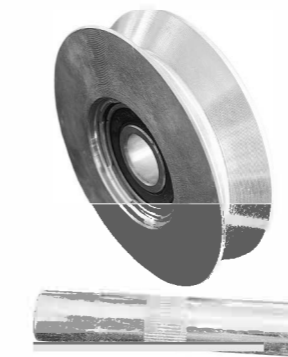

型号 Item	A	B	L	d	单重 (KG)	每箱数量 PCS/CTN	纸箱尺寸 CTN
EIV40	38	14	40	8	0.1	40	30*30*15CM
EIV50	48	15	50	12	0.15	40	30*30*15CM
EIV65	63	16	50	12	0.3	30	30*30*15CM
EIV75	73	17	70	12	0.46	20	30*30*15CM
EIV90	88	20	70	12	0.82	20	30*30*15CM
EIV100	98	22	70	12	1.02	12	30*30*15CM

▼ 吊轮 Sliding Door Roller

型号 Item	单重 (KG)	每箱数量 PCS/CTN	纸箱尺寸 CTN
DL22-A	0.35	50	29*17*19CM

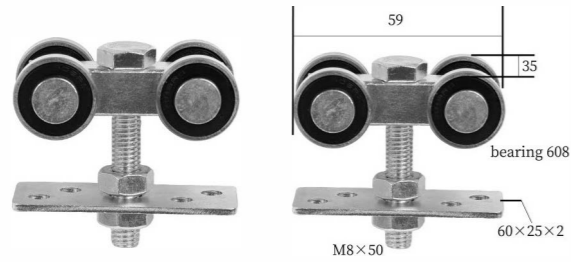

型号 Item	单重 (KG)	每箱数量 PCS/CTN	纸箱尺寸 CTN
DL25-A	0.055	400	29*17*19CM

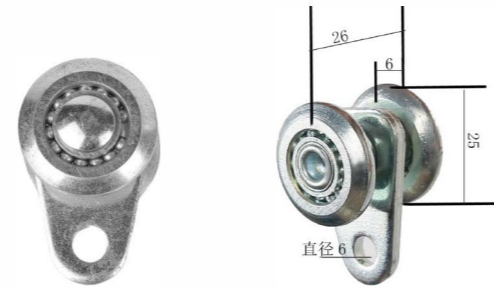

型号 Item	单重 (KG)	每箱数量 PCS/CTN	纸箱尺寸 CTN
DL25-B	0.095	150	29*17*19CM

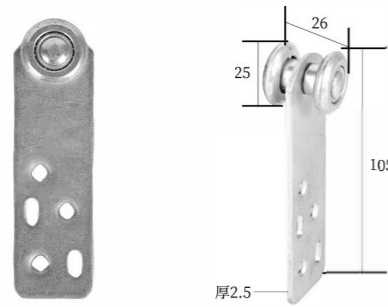

型号 Item	单重 (KG)	每箱数量 PCS/CTN		纸箱尺寸 CTN
		不带吊板	带吊板	
DL25-C	0.13/0.19	80	50	29*17*19CM

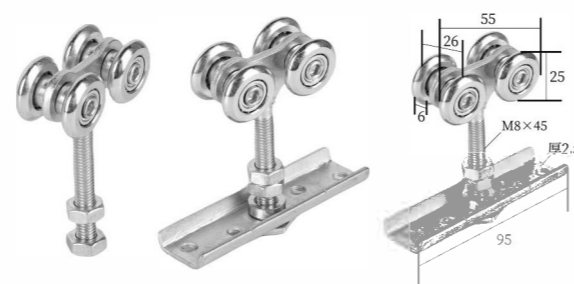

型号 Item	单重 (KG)	每箱数量 PCS/CTN	纸箱尺寸 CTN
DL25-D	0.16	80	29*17*19CM

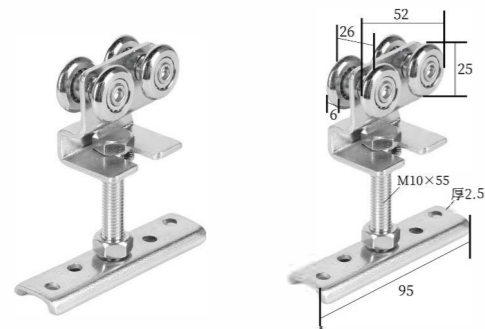

型号 Item	单重 (KG)	每箱数量 PCS/CTN	纸箱尺寸 CTN
DL25-DA	0.217	100	29*17*19CM

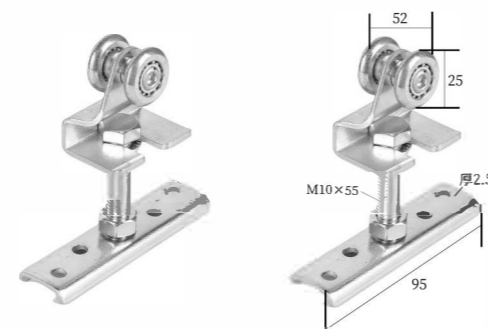

▼ 吊轮 Sliding Door Roller

型号 Item	单重 (KG)	每箱数量 PCS/CTN	纸箱尺寸 CTN
DL25-E	0.19	100	29*17*19CM

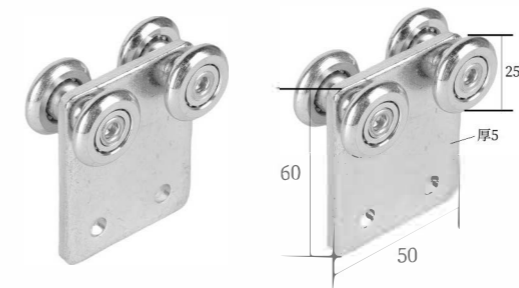

型号 Item	单重 (KG)	每箱数量 PCS/CTN	纸箱尺寸 CTN
DL25-F	0.071	250	29*17*19CM

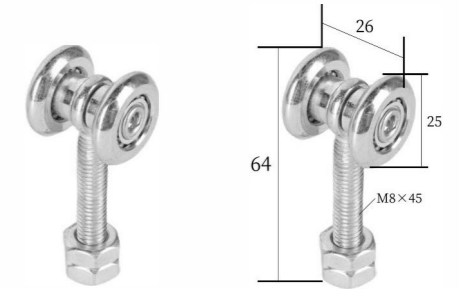

型号 Item	单重 (KG)	每箱数量 PCS/CTN		纸箱尺寸 CTN
		不带吊板	带吊板	
DL25-H	0.12/0.17	80	50	29*17*19CM



型号 Item	单重 (KG)	每箱数量 PCS/CTN	纸箱尺寸 CTN
DL31-A	0.16	100	29*17*19CM

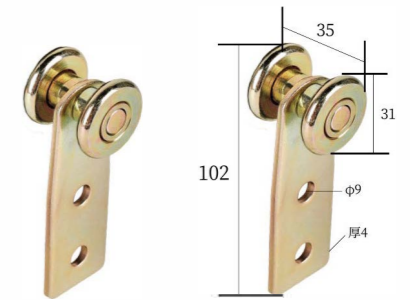

型号 Item	单重 (KG)	每箱数量 PCS/CTN	纸箱尺寸 CTN
DL38-A	0.24	100	35*19*23CM



型号 Item	单重 (KG)	每箱数量 PCS/CTN		纸箱尺寸 CTN
		不带吊板	带吊板	
DL38-C	0.43/0.54	30	25	29*17*19CM

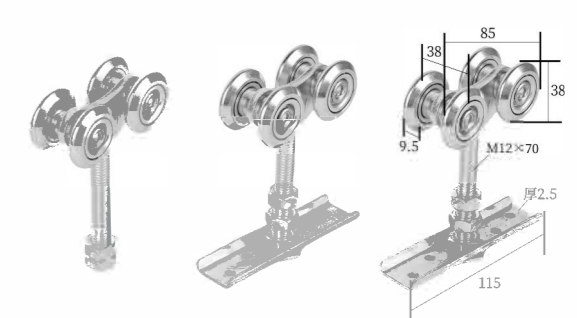

▼ 吊轮 Sliding Door Roller

型号 Item	单重 (KG)	每箱数量 PCS/CTN	纸箱尺寸 CTN
DL34-A	0.27	40	29*17*19CM

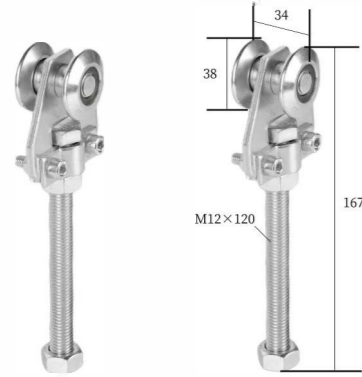

型号 Item	单重 (KG)	每箱数量 PCS/CTN	纸箱尺寸 CTN
DL34-C	0.5	25	29*17*19CM

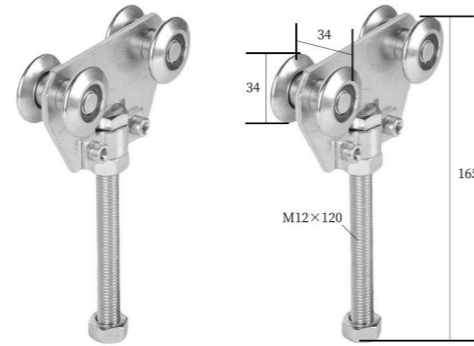

▼ 吊轮 Sliding Door Roller

型号 Item	单重 (KG)	每箱数量 PCS/CTN	纸箱尺寸 CTN
DL34-B	0.47	50	29*17*19CM

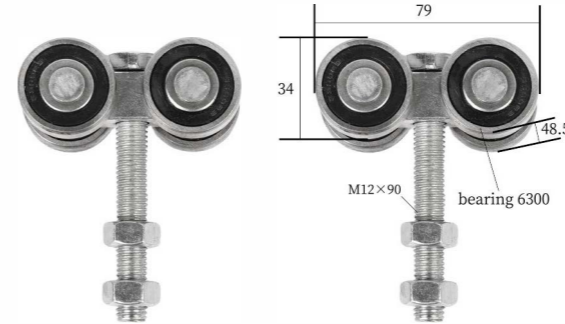

型号 Item	单重 (KG)	每箱数量 PCS/CTN	纸箱尺寸 CTN
DL48-A	0.8	25	29*17*19CM

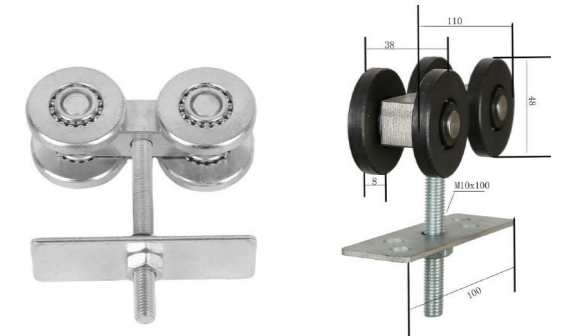

型号 Item	单重 (KG)	每箱数量 PCS/CTN	纸箱尺寸 CTN
DL42-A	0.26	100	29*17*19CM



型号 Item	单重(KG)		每箱数量PCS/CTN		纸箱尺寸 CTN
	不带吊板	带吊板	不带吊板	带吊板	
DL42-C	0.51	0.61	30	25	29*17*19CM

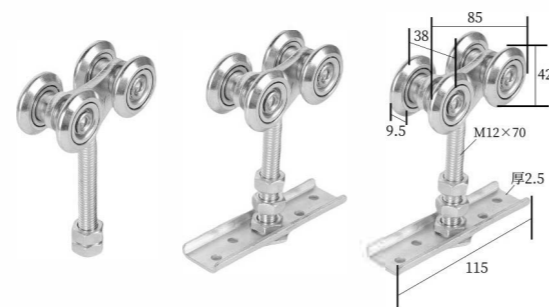

型号 Item	单重 (KG)	每箱数量 PCS/CTN	纸箱尺寸 CTN
DL55-A	0.53	40	35*19*23CM

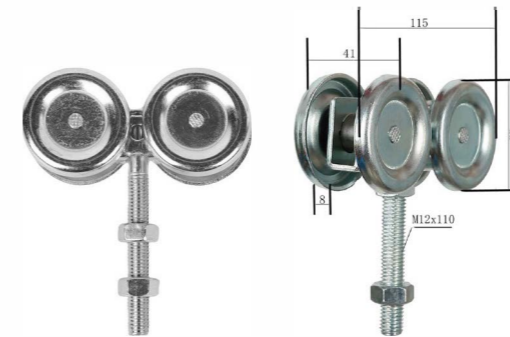

型号 Item	单重(KG)		每箱数量PCS/CTN		纸箱尺寸 CTN
	不带吊板	带吊板	不带吊板	带吊板	
DL55-B	1.28	1.45	10	15	29*17*19CM

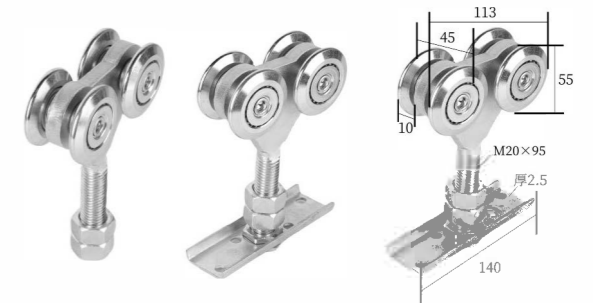

型号 Item	单重 (KG)	每箱数量 PCS/CTN	纸箱尺寸 CTN
DL46-A	0.65	30	29*17*19CM



型号 Item	单重 (KG)	每箱数量 PCS/CTN	纸箱尺寸 CTN
DL46-B	0.32	50	29*17*19CM

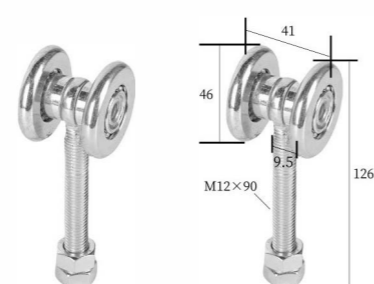

型号 Item	单重 (KG)	每箱数量 PCS/CTN	纸箱尺寸 CTN
DL55-C	0.42	40	35*19*23CM



型号 Item	单重 (KG)	每箱数量 PCS/CTN	纸箱尺寸 CTN
DL55-E	0.51	20	29*17*19CM

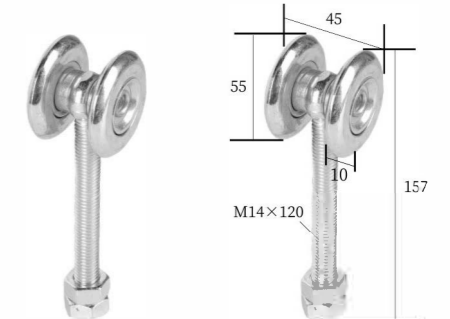

吊轮 Sliding Door Roller

型号 Item	单重 (KG)	每箱数量 PCS/CTN	纸箱尺寸 CTN
DL55-D	1.01	20	30*20*20CM

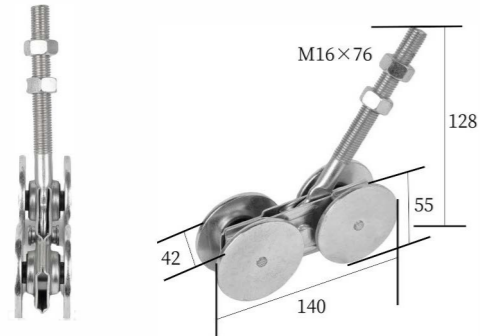

型号 Item	单重 (KG)	每箱数量 PCS/CTN	纸箱尺寸 CTN
DL75-D	1.4	10	29*17*19CM

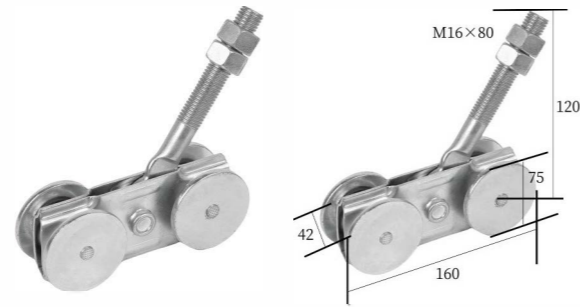

大型吊轮 Sliding Door Roller

型号 Item	单重 (KG)	每箱数量 PCS /CT N	纸箱尺寸 CT N
DL68-A	2.37	10	29*17*19CM



型号 Item	单重 (KG)	每箱数量 PCS /CT N	纸箱尺寸 CT N
DL47-A	1.41	12	31.5*18*17.5CM

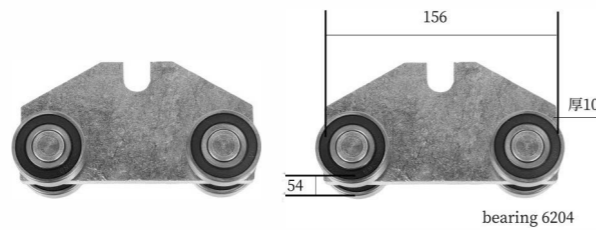

吊轮套件 Hanging wheel kit

型号 Item	单重 (KG)	每箱数量 PCS/CTN	纸箱尺寸 CTN
FL9500	3.3	8	36*28*29CM

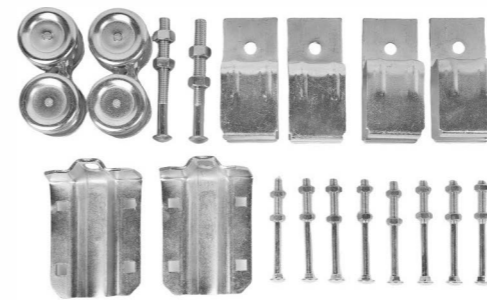

型号 Item	D (mm)	H (mm)	M (mm)	H (mm)	单重 Weight(kg)	每箱数量 PCS/CTN	纸箱尺寸 Carton(cm)
NY3530	34	30	10	41.5	0.09	100	23*13*16

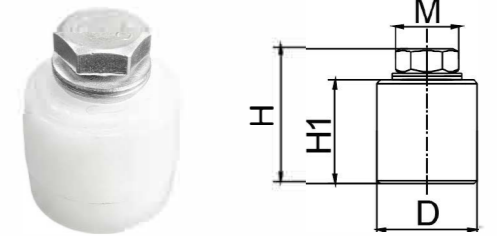

尼龙轮 Nylon Wheel



型号 Item	D(mm)	H1 (mm)	M (mm)	H(mm)	单重 Weight(kg)	每箱数量 PCS/CTN	纸箱尺寸 Carton(cm)
NY2540	25	40	10	77	0.068	120	29*17*19
NY2560	25	60	12	101	0.135	100	29*17*19
NY3040	30	40	12	77	0.12	100	29*17*19
NY3060	30	60	12	101	0.155	80	29*17*19
NY4040	40	40	12	77	0.143	70	29*17*19
NY4048	40	48	12	87	0.157	60	29*17*19
NY4060	40	60	14	104	0.23	50	29*17*19
NY40100	40	100	16	146	0.397	34	29*17*19
NY40140	40	140	16	185	0.47	25	29*17*19
NY40150	40	150	16	196	0.52	20	29*17*19
NY40200	40	200	16	245	0.63	20	30*25*15
NY40250	40	250	16	300	0.75	20	40*20*20
NY40300	40	300	16	355	0.9	20	40*20*20
NY40400	40	400	16	455	1.16	10	55*15*15
NY40500	40	500	16	555	1.38	10	60*15*15

▼ 框架 Guide Braket with Nylon wheel

型号 Item	D(mm)	H1 (mm)	L (mm)	H(mm)	S(mm)	单重 Weight(kg)	纸箱尺寸 Carton(cm)
L108	30	40	108	60	5	0.33	29*17*19

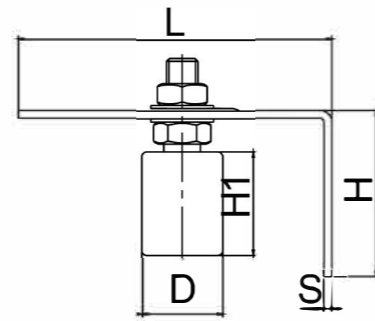

型号 Item	D(mm)	H1 (mm)	L (mm)	H(mm)	S(mm)	单重 Weight(kg)	每箱数量 PCS/CTN	纸箱尺寸 Carton(cm)
L148	30	40	148	60	5	0.49	50	40*20*20

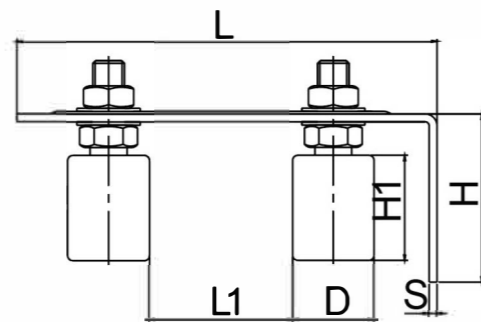

型号 Item	D(mm)	H1 (mm)	L (mm)	H(mm)	S(mm)	单重 Weight(kg)	每箱数量 PCS/CTN	纸箱尺寸 Carton(cm)
L180	40	60	180	107	8	1.33	20	40*20*20

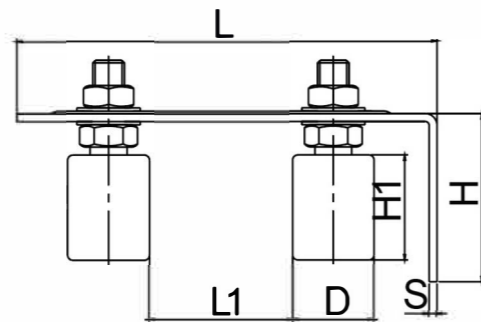

▼ 框架 Guide Braket with Nylon wheel

型号 Item	D(mm)	H1 (mm)	L (mm)	H(mm)	S(mm)	单重 Weight(kg)	每箱数量 PCS/CTN	纸箱尺寸 Carton(cm)
U140	30	40	140	45	3	0.52	20	40*20*20
U160	40	40	160	63	4	0.77	20	40*20*20
U168	30	40	168	40	5	0.56	20	40*20*20
U200	40	40	200	63	4	0.9	20	40*20*20

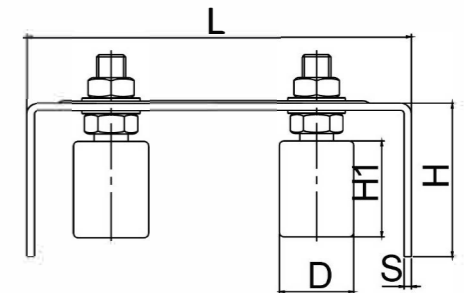

型号 Item	D(mm)	H1 (mm)	L (mm)	H(mm)	S(mm)	单重 Weight(kg)	每箱数量 PCS/CTN	纸箱尺寸 Carton(cm)
GKJ1617	30	40	160	50	3	1.62	20	35*19*23
GKJ2020	40	40	200	55	3	2.13	15	35*19*23
GKJ2022	40	40	200	55	3	2.3	15	35*19*23
GKJ2035	40	40	200	60	3	3.6	8	40*20*20
GKJ2213	30	40	220	55	3	2.15	10	35*19*23

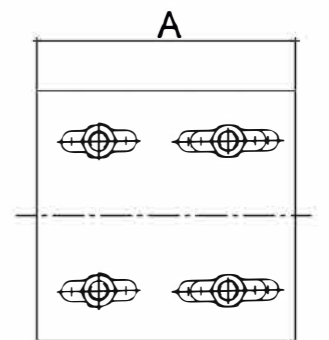
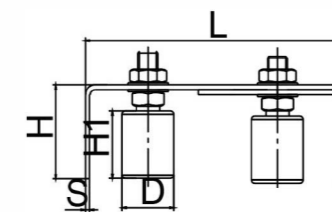
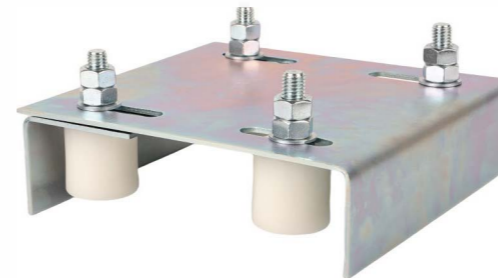

▼ 单边吊轮 Hanging Door Roller

型号 Item	D(mm)	H (mm)	A (mm)	L (mm)	S(mm)	单重 Weight(kg)	每箱数量 PCS/CTN	纸箱尺寸 Carton(cm)	轴承 Bearing
DL40	40	28	40	170	6	0.46	40	29*17*19	6203
DL52	52	31	50	170	6	0.63	30	29*17*19	6205
DL62	62	32	60	170	8	1.04	25	29*17*19	6206
DL72	72	33	80	200	10	1.7	14	29*17*19	6207
DL100	100	41	100	200	10	3	8	29*17*19	6309

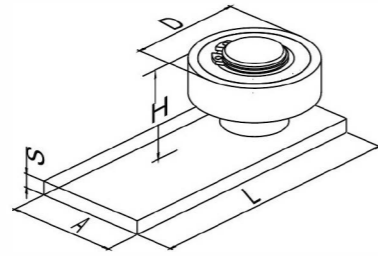

▼ 门吸 Gate Stopper

型号 Item	H (mm)	A×B (mm)	S(mm)	单重 Weight(kg)	每箱数量 PCS/CTN	纸箱尺寸 Carton(cm)
MX-01	95	100*80	8	0.52	32	54*26.5*25.5

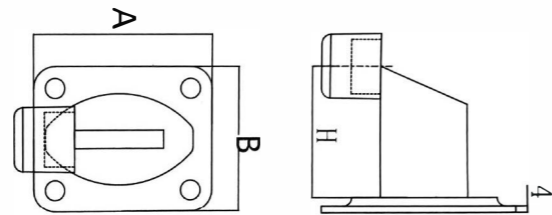
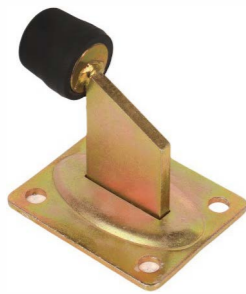

▼ 门兜 End stop

型号 Item	A (mm)	H (mm)	C(mm)	S(mm)	单重 Weight(kg)	每箱数量 PCS/CTN	纸箱尺寸 Carton(cm)
MD-01	90	103	78	4	0.925	32	54*26.5*25.5

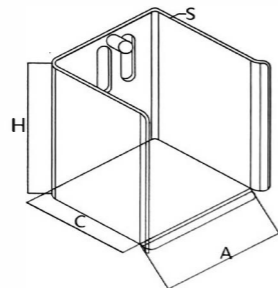

▼ Galvanized Sliding Gate Track

型号 Item	R (mm)	A (mm)	B (mm)	H (mm)	L (mm)	L1 (mm)	L2 (mm)	S (mm)	单重 Weight(kg)	包装方式
R8	8	11	6	15	55	98	28	3	1.42	托盘

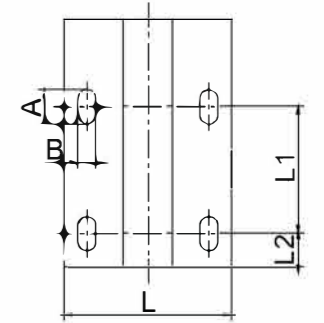
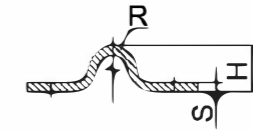

型号 Item	R (mm)	A (mm)	B (mm)	H (mm)	L (mm)	L1 (mm)	L2 (mm)	S (mm)	单重 Weight(kg)	包装方式
R10	10	11	6	15	55	98	28	3	1.42	托盘

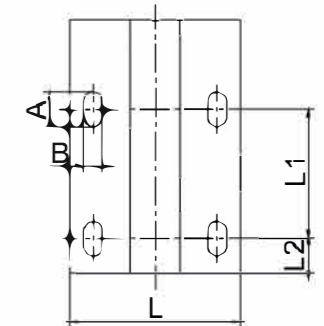
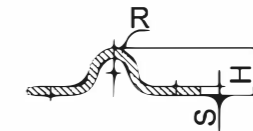

型号 Item	A (mm)	B (mm)	H (mm)	L (mm)	L1 (mm)	L2 (mm)	S (mm)	单重 Weight(kg)	包装方式
V20	11	6	15.5	56.5	98	50	3	1.42	托盘

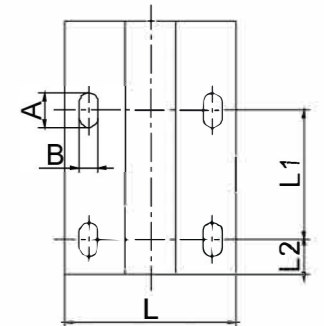
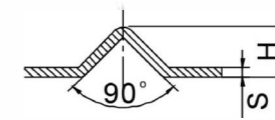

吊轨 Sliding Door Rail

型号 Item	A (mm)	H (mm)	C (mm)	S (mm)	单重 Weight(kg)	包装方式
T25V	37	34	20	1.5	1.35	托盘

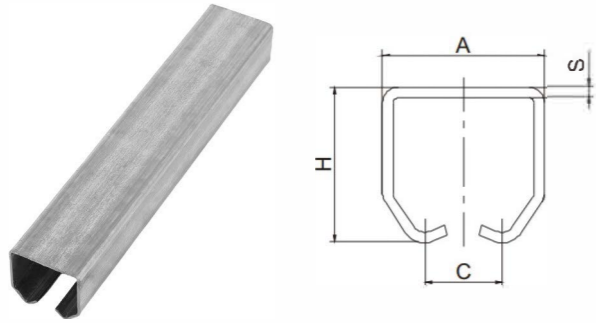

型号 Item	A (mm)	H (mm)	C (mm)	S (mm)	单重 Weight(kg)	包装方式
T25-U	37	34	10.5	1.5	1.35	托盘

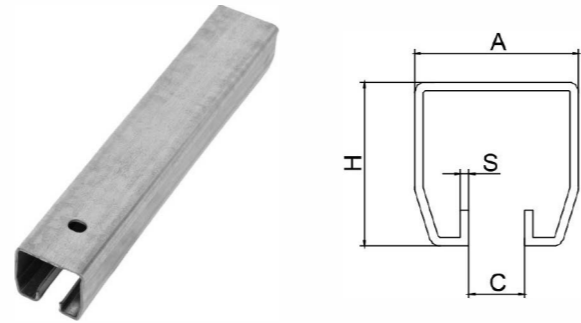

型号 Item	A (mm)	H (mm)	C (mm)	S (mm)	单重 Weight(kg)	包装方式
T38	45	48	28	2	2.4	托盘

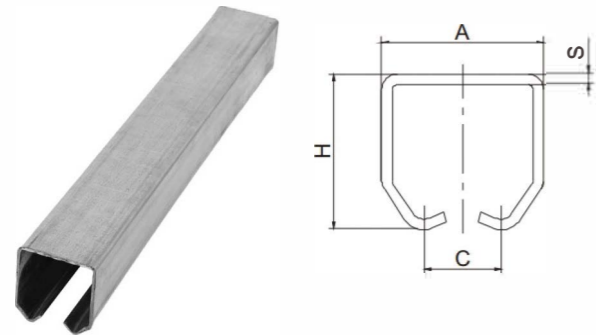

型号 Item	A (mm)	H (mm)	C (mm)	S (mm)	单重 Weight(kg)	包装方式
T55	58	65	39	2	3.05	托盘

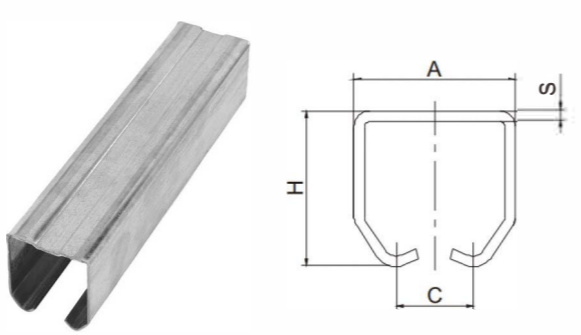

型号 Item	A (mm)	H (mm)	C (mm)	S (mm)	单重 Weight(kg)	包装方式
T62	48	62	16.5	1.5	2.35	托盘

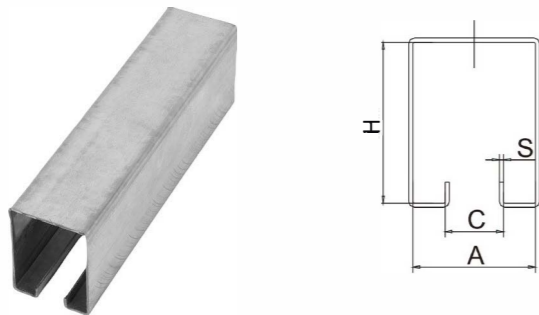

旗型铰链 (Flag hinge)

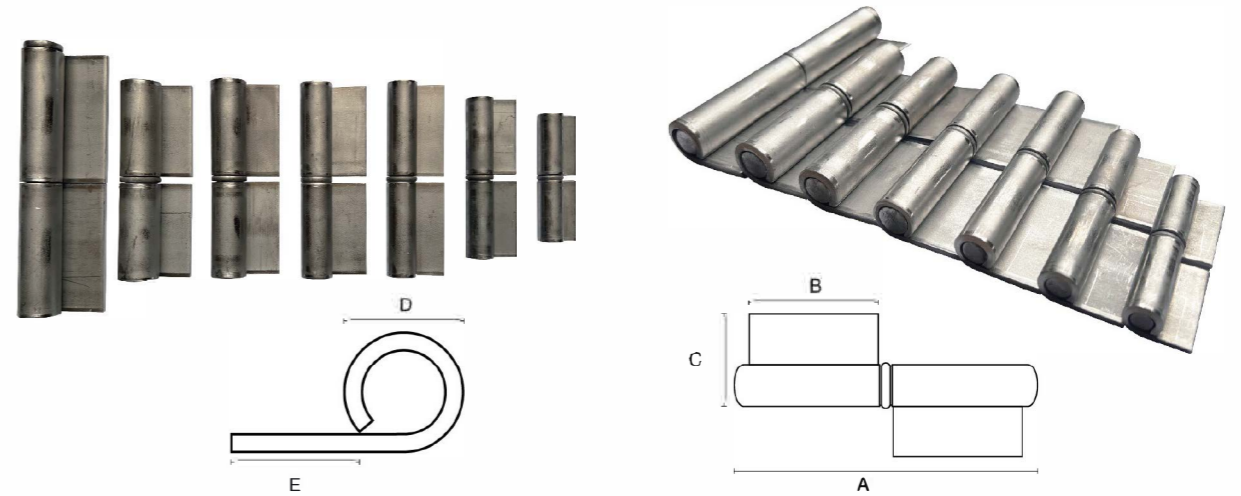

型号 Item	A(mm)	B(mm)	C(mm)	D (mm)	E(mm)	厚度(mm)	重量(g)
14*80	80	38	25	14	12	3	115
16*100-A	100	48	31	16	18	2.75	183
16*100-B	100	48	33	16	19	3	193
18*120	120	58	36	18	20	3.5	295
20*120	120	58	42	20	24	3	354
22*120	120	58	41	22	21	4	425
24*120	120	58	41	24	17	4	488
24*165	165	80	47	24	28	4	700

蝶形铰链 (Butterfly hinge)



型号 Item	A(mm)	B(mm)	厚度(mm)	重量(g)
HINGE2.5	57	89	2.5	156
HINGE3	76	76	3	184
HINGE4	97	100	4.5	515
HINGE5	126	127	4.75	861
HINGE6	151	151	4.75	1153

▼ 快拆铰链 (Quick release hinge)

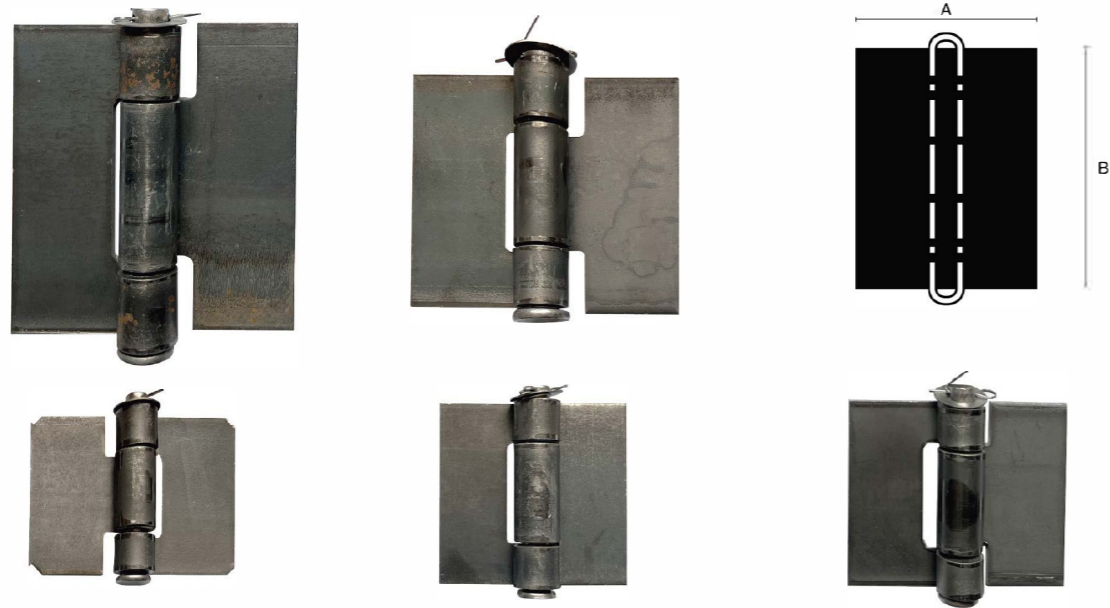

A(mm)	B(mm)	厚度(mm)	重量(g)
90	70	3.5	264
91	80	3.2	297
94	80	4	360
116	103	3.5	585
122	133	4.2	900

▼ 防盗铰链 (Anti-theft hinge)



型号Item	A(mm)	B(mm)	厚度(mm)	重量(g)
#4	94	80	4	359
#3	90	70	3.5	248



天津欧耐达传动科技有限公司

Tianjin OuNaiDa Transmissions Technology Co., Ltd

吊轮、吊轨、滑轮、滑轨、尼龙轮等五金配件，
设计、研发、生产、销售，
提供OEM、ODM、OBM等服务。